



Hills[™] CentralVac1600

Owner's Manual HCV•1600



powerful
turbine

modern
design

low noise

reduces
Allergy
symptoms

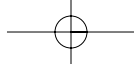

2

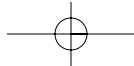
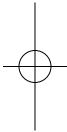
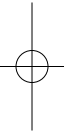



CENTRAL VACUUM SYSTEM OPERATING AND MAINTENANCE INSTRUCTIONS (Model HCV•1600)

Congratulations! You have joined the growing number of households to enjoy the many benefits of owning a Hills Central Vacuum System.

Your Hills Central Vacuum System is a lifetime improvement for you and your family. Follow these simple maintenance and care instructions for trouble free vacuuming for many years to come.

Operating Your Central Vacuum System

Inside the Home

1. Plug in the cuff end of the hose into the nearest wall inlet inside your home and the power unit will automatically turn on, ready for you to begin vacuuming. (See Figure.1)
2. When you have finished vacuuming simply unplug the cuff of the hose out of the inlet and hold the door of the inlet open for five (5) seconds until the suction subsides. This time delay is used to clear any debris from the piping system which may otherwise cause clogging.

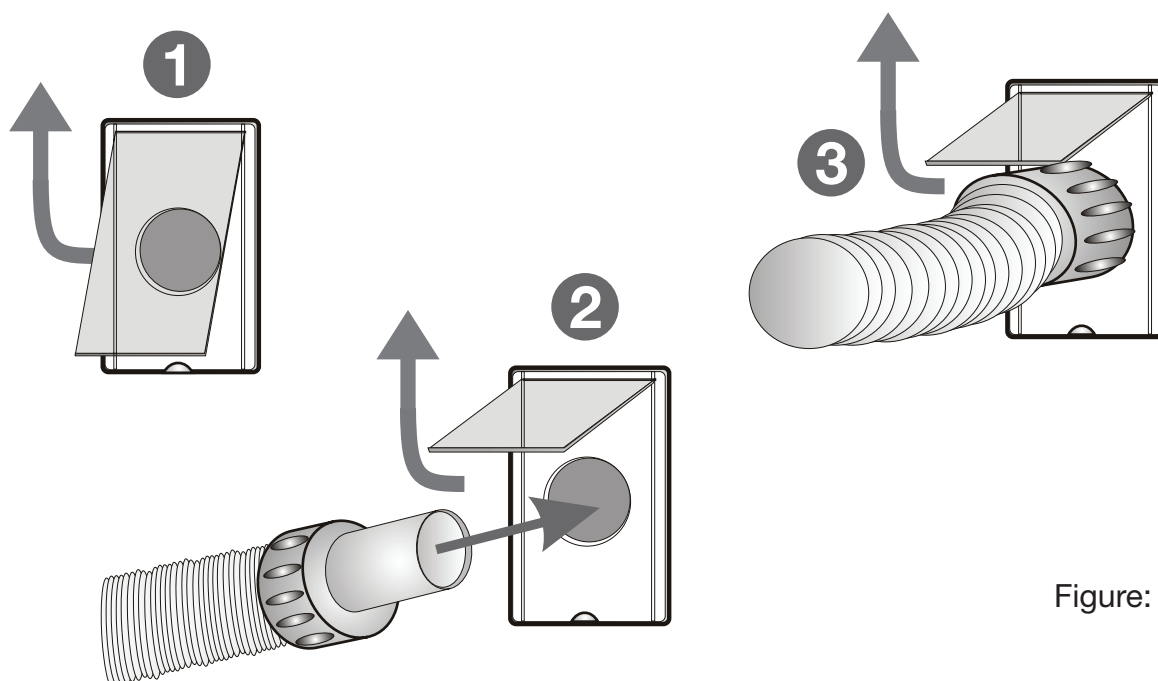

Figure: 1



AT THE VACUUM POWER UNIT

1. Insert the hose cuff into the inlet adjacent to the vacuum power unit.
2. Turn the unit on using the ON/OFF switch located on the control panel at the top of the unit. When finished, turn the switch to the OFF position again. A 5 second time delay is used to clear any debris from the hose or local piping network which may otherwise cause clogging. (See Figure. 2)
3. Remove hose from inlet to eliminate loss of suction inside the house if a second hose is used. Only one hose may be connected to the system at any time during operation.

4

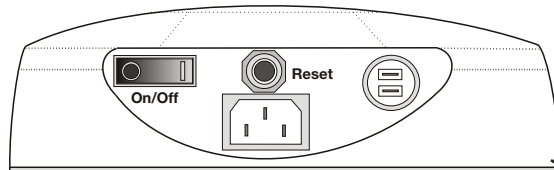

Figure: 2



MAINTENANCE & CARE OF YOUR SYSTEM

Your power unit is warranted against defective materials and workmanship but not against misuse. There is a service charge for repairing or replacing damaged or misused components of the system or for unnecessary service calls.

1. Do not suck up flammable and non-flammable liquids, chemicals, cement, lime and plaster powders.
2. Do not leave the central vacuum system on unattended.
3. Use only one inlet at a time to maintain maximum suction.
4. Hold the inlet door open for five (5) seconds after removing the hose. This will make sure that the unit has stopped and clear any residual dirt out of the pipe system.
5. Unclip the dust bucket, empty (see Figure 5D), and remove the filter by unscrewing the filter holder. If the suction is still diminished, remove and clean the filter (see Figure 5A). The filter is removed by unscrewing the filter holder (see Figure 5B).

To clean the Cartridge filter, you may attempt to remove excess dust by shaking. If this is unsuccessful and the filter is unserviceable, it should be replaced. Please note a spare filter is supplied with your new vacuum.

The filter must be reinstalled before using your vacuum. Using the vacuum without the filter could result in permanent damage to the motor and void any warranties.

6. Empty dust bucket periodically or when dust reaches 5cm from bottom of cone. (see Figure 4).
7. Do not cover the top of power unit, as this will restrict the cooling airflow, which may cause the motor to over heat. Do not use the system if a blockage occurs.

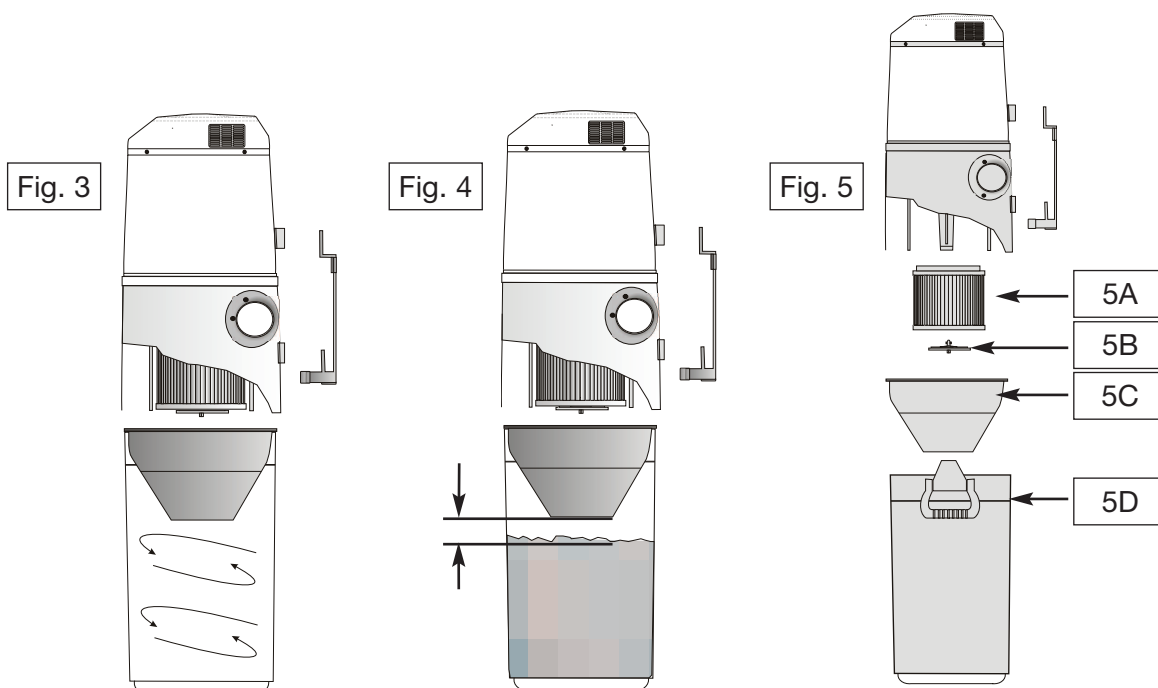



WARRANTY

This Central Vacuum has been built to Hills specification from quality materials. It is warranted to be free of defects in materials, workmanship and mechanical performance for a period of 24 months from the date of purchase.

Warranty Conditions

- This warranty applies only to the Hills Central Vacuum unit. It does not apply to piping and fittings.
- All warranty claims must be accompanied by original proof of purchase.
- The vacuum must have been used in accordance with the User Guide and maintenance instructions.
- All costs associated with the transport of goods under warranty claim are the responsibility of the claimant.
- Hills reserve the right to repair or replace goods at its own discretion.
- Hills reserve the right to act as final arbiter in all warranty claims.

6

Their warranty does not apply if the defect occurs as a result of:

- Misuse, neglect or accidental damage.
- Scratches, dents or blemishes which occur after the purchase date.
- The unit being used for any other purpose other than that for which it was designed.





Hills™ **CentralVac1600**

Your Installation Company:

Visit www.hillshomesolutions.com.au or contact Hills Consumer Advice on **1300 300 564**.

HCVUser RevA 0801 – 2008