



ELECTRONICS
DESIGN &
MANUFACTURING

Solution 6 + 6 Wireless - AE Quick Reference Guide

ISSUE 1.00

Proudly Australian

Solution 6+6 Wireless - AE

Quick Reference Guide

Copyright © 1997 by Electronics Design & Manufacturing Pty Limited
SYDNEY, AUSTRALIA

Document Part Number MA660Q

Document Issue 1.00

Printed 29 July 1997

This documentation is provided to suit *Solution 6+6 Wireless - AE* (CC660/LP660)

Firmware Revision 1.0

Hardware Version A

Alarm Link Form - S6WCV10

Copyright Notice

All rights reserved. No part of this publication may be reproduced, transmitted or stored in a retrieval system in any form or by any means, electronic, mechanical, photocopying, recording, or otherwise, without the prior written permission of Electronics Design & Manufacturing Pty Limited.

Trademarks

Throughout this document trademark names may have been used. Rather than put a trademark symbol in every occurrence of a trademark name, we state that we are using the names only in an editorial fashion and to the benefit of the trademark owner with no intention of infringement of the trademark.

Notice of Liability

While every precaution has been taken in the preparation of this document, neither Electronics Design & Manufacturing Pty Limited nor any of its official representatives shall have any liability to any person or entity with respect to any liability, loss or damage caused or alleged to be caused directly or indirectly by the information contained in this book.

Electronics Design & Manufacturing Pty Limited reserves the right to make changes to features and specifications at any time without prior notification in the interest of ongoing product development and improvement.

Introduction

Thankyou for choosing the *Solution 6+6 Wireless - AE* control panel for your installation. We are sure that you will find this control panel extremely flexible, reliable and easy to use.

Before using the control panel for the first time, we suggest that you read the section in this Quick Reference Guide called "Programming Using The Codepad" to familiarise yourself with the basic programming methodology.

The Quick Reference Guide is supplied with the control panel to provide installers with enough basic information to wire, configure and operate the control panel. Due to the control panels many programmable features and options, we suggest that you obtain the complete Installation Manual which provides detailed information on all system options and functions as well as detailed information on the numerous programming methods.

Programming

The programming options of this control panel are stored in a non volatile EPROM. This memory will hold all the relevant configuration and user specific data even during a total power loss.

The data retention time is as long as ten years without power, therefore no reprogramming will be required after powering the control panel down.

The data can be altered as many times as required without the need for any additional specialised equipment. This memory is laid out in numerous locations each of which holds the data for a specific function.

In general, the entire programming sequence will consist of nominating the location number and then entering or altering the required data. You will repeat this procedure until all the data has been altered to suit your requirements. The factory default settings have been selected for the control panel to report in Contact ID Format.

Note: '15' is the maximum value that can be programmed into any location.

There are two programming modes. The Installer's Programming Mode and the Operators Programming Mode. Both programming modes have individual access codes and these two codes must always be programmed differently. The Master Code, as well as being able to arm and disarm the system gives access to the Operators Programming Mode. The Installer's Code only gives access to the Installer's Programming Mode and does NOT arm and disarm the system.

Programming of the *Solution 6+6 Wireless - AE* control panel can be carried out via any of the following four methods.

- Remote Codepad
- Hand Held Programmer (CC814)
- Programming Key (CC891)
- Alarm Link Upload/Download Software (CC816)

Note: For further information on the different programming options available for the *Solution 6+6 Wireless - AE* control panel, refer to the Installation Manual (MA660I).

Programming Using The Remote Codepad

The control panel must be in a disarmed state with no flashing zone alarm memories to access Installer's Programming Mode. This can be achieved by entering the **MASTER CODE** followed by the **AWAY** button. The factory default Master Code is **2580**. If the control panel has become armed in the AWAY mode, simply enter the **MASTER CODE** followed by the **AWAY** button again to disarm the control panel.

To access the Installer's Programming Mode, enter the four digit **INSTALLER CODE** followed by the **AWAY** button. The factory default Installer Code is **1234**. Three beeps will be heard and both the AWAY and the STAY indicators will flash simultaneously. If a long beep is heard, check the control panel for alarm memory. The combination of the MAINS and ZONE indicators will indicate the data stored in the first location of the Primary Telephone Number (LOCATION 000).

Data Value	Zone 1 LED	Zone 2 LED	Zone 3 LED	Zone 4 LED	Zone 5 LED	Zone 6 LED	Zone 7 LED	Zone 8 LED	Mains LED
0									
1	✓								
2		✓							
3			✓						
4				✓					
5					✓				
6						✓			
7							✓		
8								✓	
9	✓							✓	
10									✓
11	✓								✓
12		✓							✓
13			✓						✓
14				✓					✓
15					✓				✓

Zone Indicators When Programming

Example

To move to a particular programming location, enter the location number required followed by the **AWAY** button. The data of the new location will now be displayed.

To move to the next location, press the **AWAY** button. This will step you to the next location and the data in that location will be displayed via the zone LED indicators.

If you press the **STAY** button without previously entering a location number, the system will step back one location.

To change data in the current location, enter the new value followed by the **STAY** button. This will store the new data into the location and still leave you still positioned at the same location.

To proceed to the next location, press the **AWAY** button. The next locations data will now be displayed.

To exit the Installer's Programming Mode, enter the command **960** followed by the **AWAY** button. Two beeps will be heard and the system will return to normal.

For a more detailed explanation, refer to the *Solution 6+6 Wireless - AE Installation Manual (MA660I)*

Note: The valid address range for a *Solution 6+6 Wireless - AE* control panel is 000 to 213.

Quick Start

The following steps will enable you to use the *Solution 6+6 Wireless - AE* control panel with the default values as set at the factory. The default settings allow the panel to communicate in Contact ID Format.

1. Connect AC power to the unit.

The MAINS indicator will remain on as will the AWAY indicator. The unit is now in the armed state.

2. The battery should now be connected.

3. Enter the default Master Code **2580** followed by the **AWAY** button. The AWAY indicator will extinguish. The control panel is now in the disarmed state. Installer's Programming Mode can now be accessed.

4. Enter the factory default Installer Code **1234** followed by the **AWAY** button. The STAY and AWAY indicator's will now flash simultaneously. Refer to "LOCATION 56 - 59" for the locations of the factory default Installer's Code.

5. Enter the primary, secondary telephone numbers and the Subscriber ID Number.

6. Set the time for the test reports if this option is required. Any other programming changes required can also be programmed, otherwise the programmed factory default settings will be used.

7. Enter command **960** followed by the **AWAY** button to exit Installer's Programming Mode. The panel will return to the disarmed state and is now ready for use. Refer to "Installer's Programming Commands" on page 6 for further commands that can be performed during access of Installer's Programming Mode.

8. If the FAULT indicator on the remote codepad has illuminated or is flashing, a system fault has occurred. To clear any system fault that may have occurred, refer to "Fault Analysis Mode" on page 7 for more information.

9. This step is optional however it use is recommended. Using a Master Code set the date and time.

- Enter **MASTER CODE** + **6** + **AWAY**.
- Enter the day of the month, then the month, then the year, then the hour, then the minute using the format (DD, MM, YY, HH, MM).
- Press the **AWAY** button when the date and time has been entered.

Zone Default Settings

The default zone settings are as listed in the table below.

Zone No.	Zone Type
1	Delay
2 & 3	Handover
4 & 5	Instant
6	24 Hour

Note: The example given in this Quick Reference Guide is a simplified description of how to configure the panel. The system offers many other programmable features which are described in greater detail in the *Solution 6+6 Wireless - AE Installation Manual (MA660I)*.

Installer's Programming Commands

There are several commands that can be invoked to perform the functions as listed below. These commands only operate when you have accessed the Installers Programming Mode. To invoke the command required, enter the corresponding numerical code followed by the **AWAY** button.

Command	Function
958	Enable and Disable Zone Status Mode
959	Test Programming Key
960	Exit Installer's Programming Mode
961	Set Defaults For Contact ID Format (Factory Default Settings)
962	Copy The Panel Memory To The Programming Key
963	Copy The Programming Key Data To The Panel Memory
964	Erase Programming Key
965	Set Up Domestic Dialling Format
966	Enable and Disable Automatic Stepping Of Locations During Programming
999	This Command Displays The Control Panel's "Software Version" Number Using The Hand Held Programmer

Installers Programming Commands

Installer Code Functions

Installer Code Functions are designed to allow the installer to perform various system tests without the need to know a Master Code.

The **INSTALLER CODE** is entered followed by a **FUNCTION** digit then the **AWAY** button to enter you into a particular mode.

INSTALLER CODE + **FUNCTION** + **AWAY**

These functions can only be carried out when the control panel is disarmed.

Function	Description
0	Fault Analysis Mode
1	Enable/Disable Wireless Zones
2	Set Number Of Days Until The First Test Report
3	Event Memory Recall Mode
4	Walk Test Mode
5	Satellite Siren Service Mode
6	Initiate A Modem Call
7	Turning Telephone Monitor Mode On and Off
8	<i>Reserved</i>
9	Send A Test Report

Installer Code Functions

Master Code Functions

Master Code Functions are designed to allow those users that have the appropriate access level to perform certain functions of a supervisory level. These functions can only be carried out when the system is disarmed.

MASTER CODE + **FUNCTION** + **AWAY**

Function	Description
0	Arming and Disarming Both Areas At The Same Time
1	Changing and Deleting User Codes/Remote Radio User Codes
2	Changing Domestic Phone Numbers
3	Event Memory Recall Mode
4	Walk Test Mode
5	Fault Analysis Mode
6	Setting The Date and Time
7	Turning Day Alarm On and Off
8	Reset Latched Outputs
9	Initiate A Modem Call

Master Code Functions

Fault Analysis Mode

There are various system faults that can be detected by the control panel. When any of these are present the FAULT indicator will begin to flash and the codepad will beep once every minute. Hold the **5** button down for two seconds until two beeps are heard. The STAY and AWAY indicators will begin to flash in unison with the FAULT indicator. One or more zone indicators (1-8) will illuminate to indicate the system fault. Refer to the following table for the list of different system faults that may occur.

Zone Indicator	Description
1	Low Battery
2	Date and Time
3	Sensor Watch
4	Horn Speaker Monitor
5	Reserved
6	E ² Fault
7	Zone Transmitter Low Battery
8	Communications Failure

Fault Types

User Code Functions

USER CODE + **FUNCTION** + **AWAY**

Function	Description
0	Arming and Disarming Both Areas At The Same Time

Hold Down Functions

Hold Down Functions have been incorporated to allow easy activation of specific operations. When a button is held down for two seconds, two beeps will be heard and a particular function will operate. These functions are listed below.

<i>Function</i>	<i>Description</i>
AWAY	Arm The System In AWAY Mode
STAY	Arm The System In STAY Mode
0	<i>Reserved</i>
1	Horn Speaker Test
2	Bell Test
3	Strobe Test
4	Turning Day Alarm On and Off
5	Fault Analysis Mode
6	Initiate a Modem Call
7	Reset Latching Outputs
8	Codepad ID Beeper Tone Change
9	Initiate A Test Report

Hold Down Functions

Each zone contains five locations. The first four locations determine how the zone operates, while the last location contains the dialler reporting information.

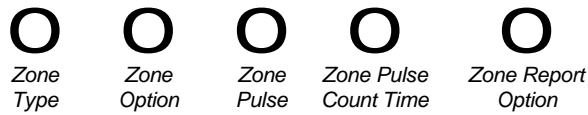

Zone Types

There are thirteen different zone types to choose from. Each has the ability to be programmed as any of the types listed below.

Type	Description	Type	Description
0	Instant	8	Delay 1 + Isolated In STAY Mode
1	Handover	9	Delay 2 + Isolated In STAY Mode
2	Delay 1	10	Reserved
3	Delay 2	11	Keyswitch
4	Reserved	12	24 Hour
5	Reserved	13	24 Hour Fire
6	Instant + Isolated In STAY Mode	14	Chime Only (follow me)
7	Handover + Isolated In STAY Mode	15	Zone Not Used

Zone Options

Option	Description
1	Lockout Siren
2	Lockout Dialler
4	Silent Alarm
8	Sensor Watch

Keyswitch Zone Options

Option	Description
1	Arm Only
2	Disarm Only
4	Enabled = Arm In STAY mode Disabled = Arm In AWAY mode
8	Enabled = Momentary operation Disabled = Toggle operation

Pulse Count Settings

The pulse count settings for each zone can be programmed between 0 - 15.

Pulse Count Time

Zone time is the time frame or period over which the number of pulses must register.

20ms Loop Response Time		150ms Loop Response Time	
0	0.5 Seconds	8	20 Seconds
1	1 Second	9	30 Seconds
2	2 Seconds	10	40 Seconds
3	3 Seconds	11	50 Seconds
4	4 Seconds	12	60 Seconds
5	5 Seconds	13	90 Seconds
6	10 Seconds	14	120 Seconds
7	15 Seconds	15	200 Seconds

Zone Descriptions

Zone	Description	Tamper Zones Description
1		
2		
3		
4		
5		
6		

Location 00 - 15

Primary Telephone Number

0	0	0	0	0	0	0	0	0	0	0	0	0	0	0	0
---	---	---	---	---	---	---	---	---	---	---	---	---	---	---	---

Location 16 - 31

Secondary Telephone Number

0	0	0	0	0	0	0	0	0	0	0	0	0	0	0	0
---	---	---	---	---	---	---	---	---	---	---	---	---	---	---	---

Location 32 - 47

Callback Telephone Number

0	0	0	0	0	0	0	0	0	0	0	0	0	0	0	0
---	---	---	---	---	---	---	---	---	---	---	---	---	---	---	---

Location 48

Dialling Format

- | | |
|-------------------------------------|--------------------------------------|
| 1 = Australian DTMF | 4 = International DTMF |
| 2 = Australian Decadic | 5 = Reversed Decadic |
| 3 = Alternate DTMF & Decadic (Aus.) | 6 = Alternate DTMF & Reverse Decadic |

1

Location 49

Handshake Tone

- | | |
|-----------------------------------|---------------------------|
| 1 = Hi-Lo Handshake (Contact ID) | 4 = No Handshake Required |
| 2 = 1400 Hz (Ademco TX @ 1900 Hz) | 5 = Pager |
| 3 = 2300 Hz (Sescoa TX @ 1800 Hz) | |

1

Location 50

Transmission Format

- | | | |
|----------------|---------------|------------------|
| 1 = Contact ID | 6 = Reserved | 11 = Domestic |
| 2 = Reserved | 7 = Reserved | 12 = Basic Pager |
| 3 = Reserved | 8 = Reserved | 13 = Reserved |
| 4 = Reserved | 9 = Reserved | 14 = Reserved |
| 5 = Reserved | 10 = Reserved | 15 = Reserved |

1

Location 51

Reserved

0

Location 52 - 55

Subscriber ID Number

0	0	0	0
---	---	---	---

Location 56 - 59

Installer Code

1	2	3	4
---	---	---	---

Location 60

Ring Count

- 15 = Answering Machine Bypass 1
14 = Answering Machine Bypass 2

8

Location 61 - 100

User Codes

	<i>User Code #1</i>	<i>Location 61 - 65</i>	<i>User Code #2</i>	<i>Location 66 - 70</i>																
	<table border="1"><tr><td>2</td><td>5</td><td>8</td><td>0</td></tr></table>	2	5	8	0	<table border="1"><tr><td>8</td></tr></table>	8	<table border="1"><tr><td>15</td><td>15</td><td>15</td><td>15</td></tr></table>	15	15	15	15	<table border="1"><tr><td>0</td></tr></table>	0						
2	5	8	0																	
8																				
15	15	15	15																	
0																				
<i>User Code #3</i>	<i>Location 71 - 75</i>	<i>User Code #4</i>	<i>Location 76 - 80</i>	<i>User Code #5</i>	<i>Location 81 - 85</i>															
<table border="1"><tr><td>15</td><td>15</td><td>15</td><td>15</td></tr></table>	15	15	15	15	<table border="1"><tr><td>0</td></tr></table>	0	<table border="1"><tr><td>15</td><td>15</td><td>15</td><td>15</td></tr></table>	15	15	15	15	<table border="1"><tr><td>0</td></tr></table>	0	<table border="1"><tr><td>15</td><td>15</td><td>15</td><td>15</td></tr></table>	15	15	15	15	<table border="1"><tr><td>0</td></tr></table>	0
15	15	15	15																	
0																				
15	15	15	15																	
0																				
15	15	15	15																	
0																				
<i>User Code #6</i>	<i>Location 86 - 90</i>	<i>User Code #7</i>	<i>Location 91 - 95</i>	<i>User Code #8</i>	<i>Location 96 - 100</i>															
<table border="1"><tr><td>15</td><td>15</td><td>15</td><td>15</td></tr></table>	15	15	15	15	<table border="1"><tr><td>0</td></tr></table>	0	<table border="1"><tr><td>15</td><td>15</td><td>15</td><td>15</td></tr></table>	15	15	15	15	<table border="1"><tr><td>0</td></tr></table>	0	<table border="1"><tr><td>0</td><td>15</td><td>15</td><td>15</td></tr></table>	0	15	15	15	<table border="1"><tr><td>1</td></tr></table>	1
15	15	15	15																	
0																				
15	15	15	15																	
0																				
0	15	15	15																	
1																				

Location 101

Day Alarm Mask

- 1 = Zone 1
2 = Zone 2
4 = Zone 3
8 = Zone 4

1

Location 102

Code Retries

6

Location 103

EOL Resistor Value

- | | | | |
|----------|----------|---------------|------------------------------|
| 1 = 1KW | 5 = 3K9W | 9 = 10KW | 13 = Reserved |
| 2 = 1K5W | 6 = 4K7W | 10 = 12KW | 14 = Reserved |
| 3 = 2K2W | 7 = 5K6W | 11 = 22KW | 15 = Split EOL For 6 Tampers |
| 4 = 3K3W | 8 = 6K8W | 12 = Reserved | |

4

Location 104 - 133
Zones

Zone #1	Location 104 - 108	Zone #3	Location 114 - 118	Zone #5	Location 124 - 128															
	<table border="1"><tr><td>2</td><td>0</td><td>0</td><td>0</td><td>3</td></tr></table>	2	0	0	0	3		<table border="1"><tr><td>1</td><td>0</td><td>0</td><td>0</td><td>3</td></tr></table>	1	0	0	0	3		<table border="1"><tr><td>0</td><td>0</td><td>0</td><td>0</td><td>3</td></tr></table>	0	0	0	0	3
2	0	0	0	3																
1	0	0	0	3																
0	0	0	0	3																
Zone #2	Location 109 - 113	Zone #4	Location 119 - 123	Zone #6	Location 129 - 133															
	<table border="1"><tr><td>1</td><td>0</td><td>0</td><td>0</td><td>3</td></tr></table>	1	0	0	0	3		<table border="1"><tr><td>0</td><td>0</td><td>0</td><td>0</td><td>3</td></tr></table>	0	0	0	0	3		<table border="1"><tr><td>12</td><td>0</td><td>0</td><td>0</td><td>3</td></tr></table>	12	0	0	0	3
1	0	0	0	3																
0	0	0	0	3																
12	0	0	0	3																

<table border="1"><tr><td> </td></tr></table>		<table border="1"><tr><td> </td></tr></table>		<table border="1"><tr><td> </td></tr></table>		<table border="1"><tr><td> </td></tr></table>		<table border="1"><tr><td> </td></tr></table>		Report Option
Type	Option	Pulse	Time	Report Option	1 = Enable Alarm Report	4 = Reserved				
					2 = Enable Restore Report	8 = Reserved				

Location 134
Report Options 1

- 1 = Enable Zone Bypass Reports
- 2 = Enable Zone Bypass Restore Reports
- 4 = Enable Zone Trouble Reports
- 8 = Enable Zone Trouble Restore Reports

15

Location 135
Report Options 2

- 1 = Enable Duress Reports
- 2 = Enable Panic, Medical and Fire Reports
- 4 = Enable Access Denied Reports
- 8 = Enable Test Reports

15

Location 136
Report Options 3

- 1 = Enable AC Mains Fail Report
- 2 = Enable Low Battery Reports
- 4 = Enable Sensor Watch Reports
- 8 = Enable Opening/Closing Reports

15

Location 137 - 139
Test Reporting Time (Repeat Days, Hours Tens, Hours Units)

0	0	0
---	---	---

Location 140 - 163
Output Configurations

Output #1	Location 140 - 145	Strobe	Location 146 - 151												
	<table border="1"><tr><td>1</td><td>14</td><td>0</td><td>0</td><td>0</td><td>0</td></tr></table>	1	14	0	0	0	0		<table border="1"><tr><td>2</td><td>0</td><td>1</td><td>0</td><td>0</td><td>0</td></tr></table>	2	0	1	0	0	0
1	14	0	0	0	0										
2	0	1	0	0	0										
Relay	Location 152 - 157	Console	Location 158 - 163												
	<table border="1"><tr><td>1</td><td>15</td><td>1</td><td>0</td><td>0</td><td>0</td></tr></table>	1	15	1	0	0	0		<table border="1"><tr><td>0</td><td>12</td><td>2</td><td>1</td><td>0</td><td>1</td></tr></table>	0	12	2	1	0	1
1	15	1	0	0	0										
0	12	2	1	0	1										

<table border="1"><tr><td> </td><td> </td></tr></table>			<table border="1"><tr><td> </td></tr></table>		<table border="1"><tr><td> </td></tr></table>		<table border="1"><tr><td> </td><td> </td></tr></table>		
Event Type (when)	Polarity (how)	Time (base)	Time (multiplier)						

Location 164 - 165
Entry Timer 1 (Seconds, 16 Seconds)

10	0
----	---

Location 166 - 167
Entry Timer 2 (Seconds, 16 Seconds)

4	1
---	---

Location 168 - 169
Exit Timer (Seconds, 16 Seconds)

12	3
----	---

<i>Location 170 - 171</i>		
Entry Guard Timer (Seconds, 16 Seconds)		<input type="text" value="12"/> <input type="text" value="3"/>
<i>Location 172 - 173</i>		
Sensor Watch Time (Days)		<input type="text" value="0"/> <input type="text" value="0"/>
<i>Location 174</i>		
Codepad Lockout Time (10 Second)		<input type="text" value="0"/>
<i>Location 175</i>		
Siren Run Time (Minutes)		<input type="text" value="10"/>
<i>Location 176</i>		
Siren Sound Rate (Slow <-Sound-> Fast)		<input type="text" value="7"/>
<i>Location 177</i>		
Swinger Shutdown Count		<input type="text" value="0"/>
<i>Location 178</i>		
Dialler Options 1	1 = Enable Dialler Reporting Functions 2 = Enable Remote Arming Via The Telephone 4 = Enable Remote Connect Via Upload/Download Software 8 = Terminate "Upload/Download" Session On Alarm	<input type="text" value="5"/>
<i>Location 179</i>		
Dialler Options 2	1 = Send Open/Close Reports Only If A Previous Alarm Has Occurred 2 = Enable First To Open, Last To Close Reporting (Partitioning Only) 4 = Send Open/Close Reports When In STAY Mode 8 = Delay Siren Until Transmission Is Complete	<input type="text" value="0"/>
<i>Location 180</i>		
System Options 1	1 = Enable Forced Arming 2 = Enable Smart Lockout 4 = Enable Monitoring Of Horn Speaker 8 = Allow Horn Speaker Beeps For Radio Remote Control Operation	<input type="text" value="1"/>
<i>Location 181</i>		
System Options 2	1 = Enable Radio Key/Keypad Interface or Night Arm Station 2 = Enable Handover Delay To Be Sequential 4 = Enable Codepad Panic To Be Silent 8 = Enable Access Denied To Be Silent	<input type="text" value="2"/>
<i>Location 182</i>		
System Options 3	1 = Enable Main Codepad To Display Data For Area #1 2 = Enable Resetting Of Sirens From Both Areas 4 = Ignore AC Fail 8 = Enable Handover Of Zone Pulse Count	<input type="text" value="0"/>
<i>Location 183</i>		
System Options 4	1 = Enable AC Fail In 1 hour 2 = Extend Time To Wait For Handshake From 30 Seconds To 1 Minute 4 = Enable Control Panel To Power Up In The Disarmed State 8 = Enable Remote Radio Zone Low Battery Reports	<input type="text" value="0"/>
<i>Location 184</i>		
Consumer Options 1	1 = Send Test Reports Only When The System Is Armed 2 = Enable Operation Of Siren & Strobe In STAY Mode 4 = Enable Answering Machine Bypass To Work Only When Armed 8 = Enable Codepad Extinguish Mode	<input type="text" value="2"/>
<i>Location 185</i>		
Consumer Options 2	1 = Enable "User Code + 0 + AWAY" Function To Arm/Disarm BOTH Areas At The Same Time 2 = Enable Single Button Arming In AWAY and STAY Modes 4 = Enable Single Button Disarming From STAY Mode 8 = Enable Alarm Memory Reset On Disarm	<input type="text" value="0"/>
<i>Location 186 - 191</i>		
Area 1 Zone Allocations		<input type="text" value="0"/> <input type="text" value="0"/> <input type="text" value="0"/> <input type="text" value="0"/> <input type="text" value="0"/> <input type="text" value="0"/>

Location 192 - 197
Area 2 Zone Allocations

0	0	0	0	0	0
---	---	---	---	---	---

Location 198 - 205
Area/User Allocations

Location 198 Areas For User # 1 <input type="text" value="0"/>	Location 199 Areas For User # 2 <input type="text" value="0"/>	Location 200 Areas For User # 3 <input type="text" value="0"/>	Location 201 Areas For User # 4 <input type="text" value="0"/>
Location 202 Areas For User # 5 <input type="text" value="0"/>	Location 203 Areas For User # 6 <input type="text" value="0"/>	Location 204 Areas For User # 7 <input type="text" value="0"/>	Location 205 Areas For User # 8 <input type="text" value="0"/>

Location 206 - 213
Radio User Allocations

Location 206 Areas For User # 9 <input type="text" value="0"/>	Location 207 Areas For User # 10 <input type="text" value="0"/>	Location 208 Areas For User # 11 <input type="text" value="0"/>	Location 209 Areas For User # 12 <input type="text" value="0"/>
Location 210 Areas For User # 13 <input type="text" value="0"/>	Location 211 Areas For User # 14 <input type="text" value="0"/>	Location 212 Areas For User # 15 <input type="text" value="0"/>	Location 213 Areas For User # 16 <input type="text" value="0"/>

Location 900
Disable Factory Default

0 = Defaulting Enabled
15 = Defaulting Disabled

0

Wiring Diagram

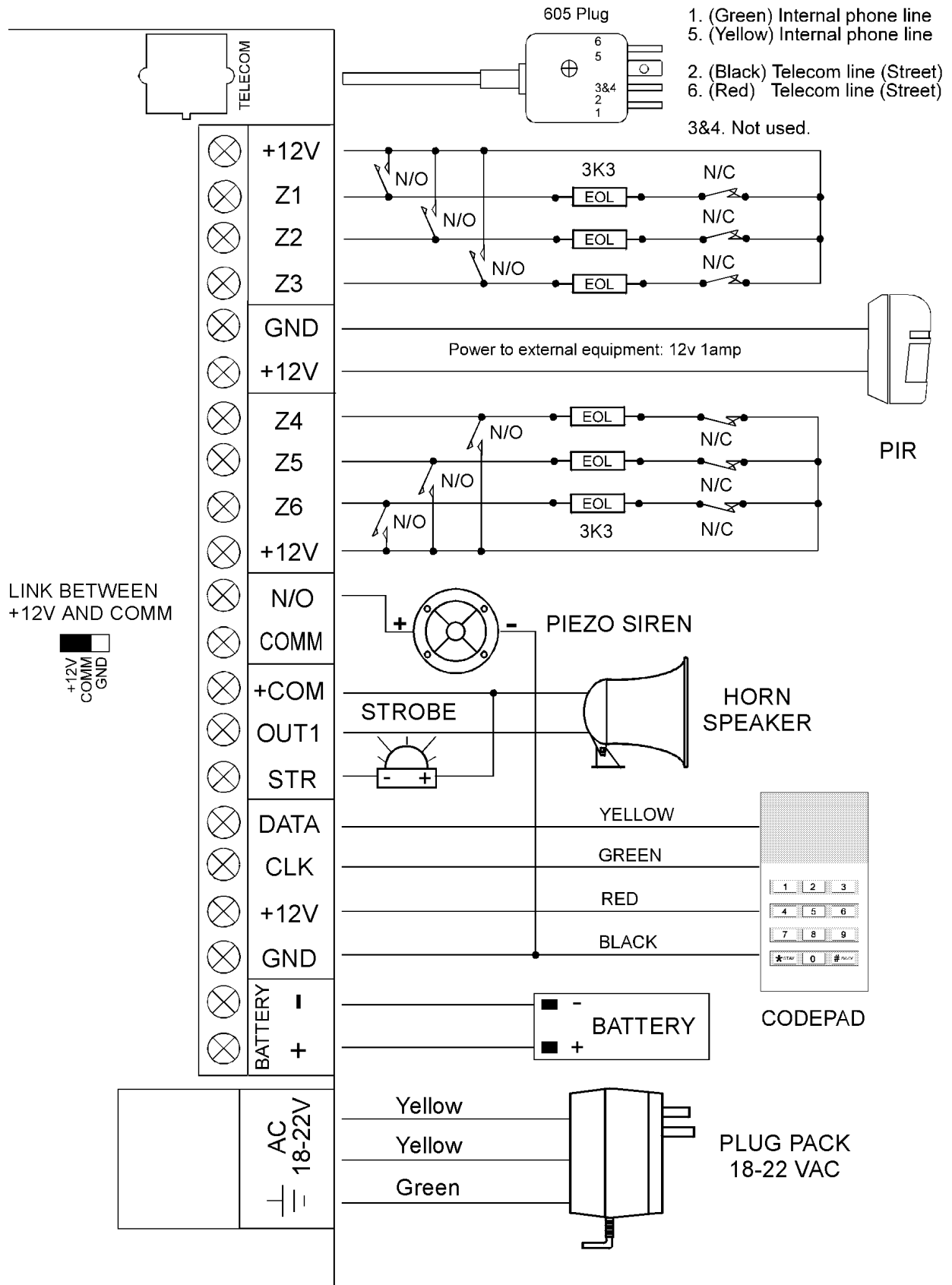

Component Overlay

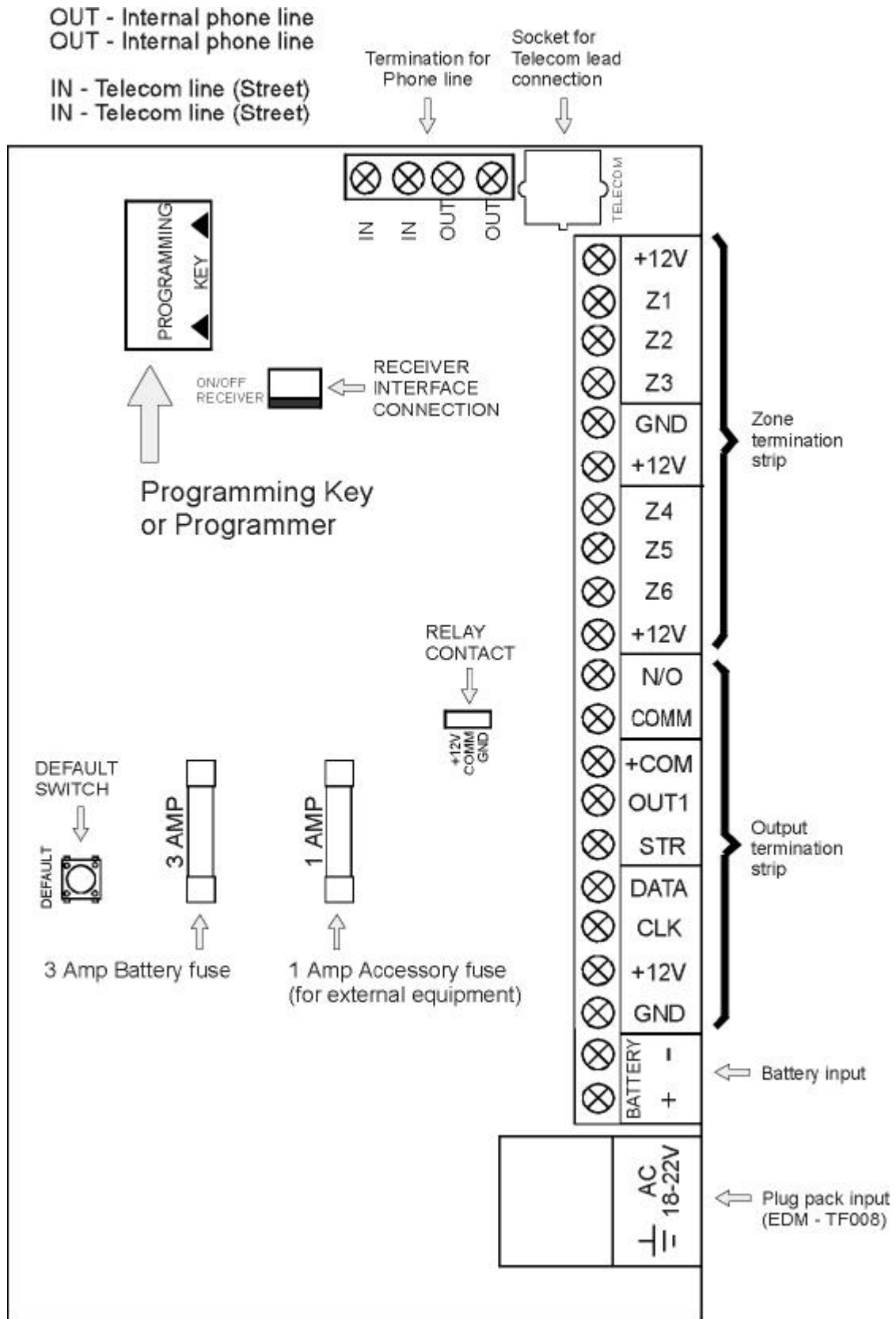

Connection Diagram For Radio Receiver

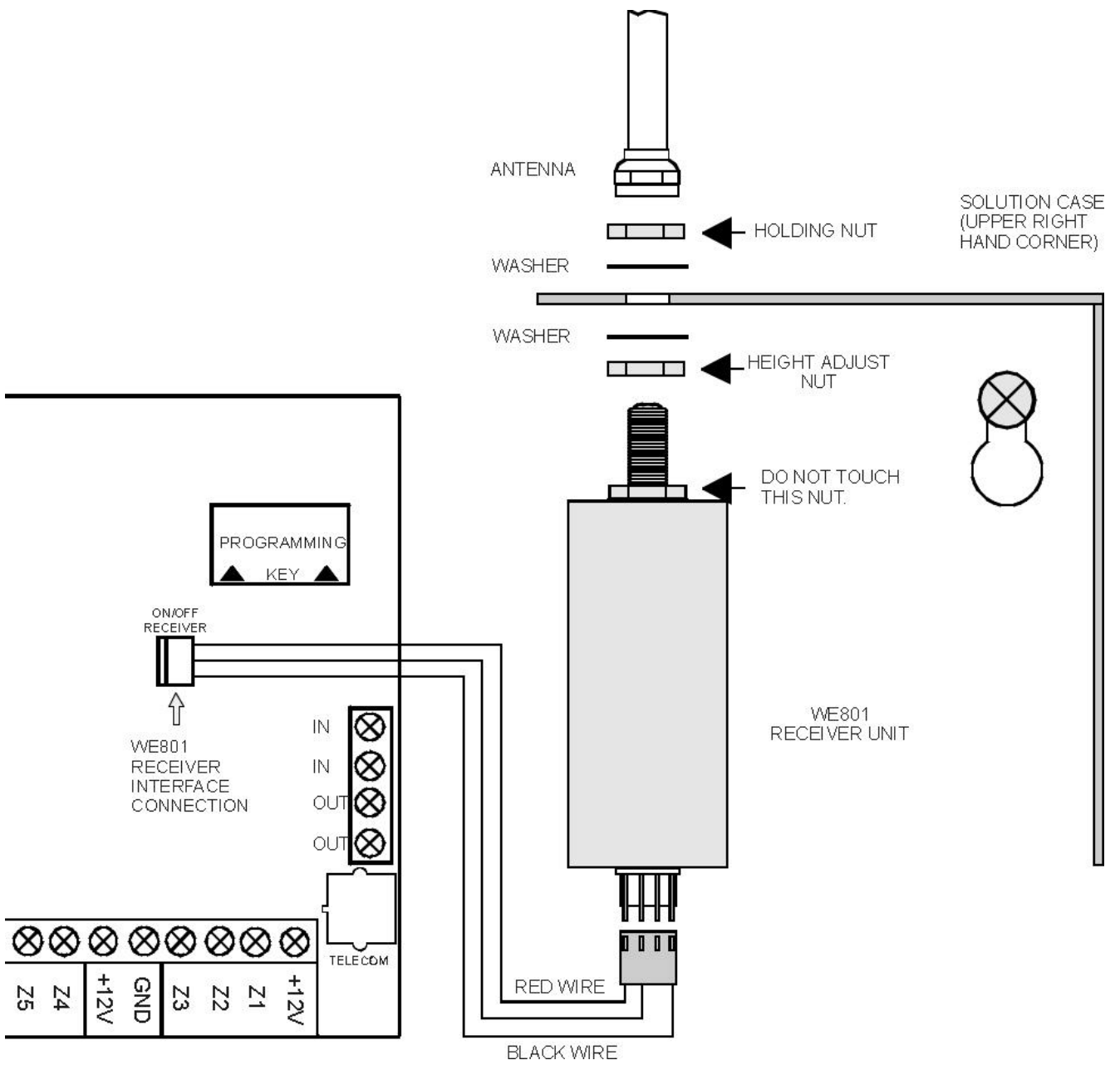

Connections Of Split EOL Resistors For Tamper Operation

Normal/Tamper zone (3K3/6K8) configuration using N/C switches.

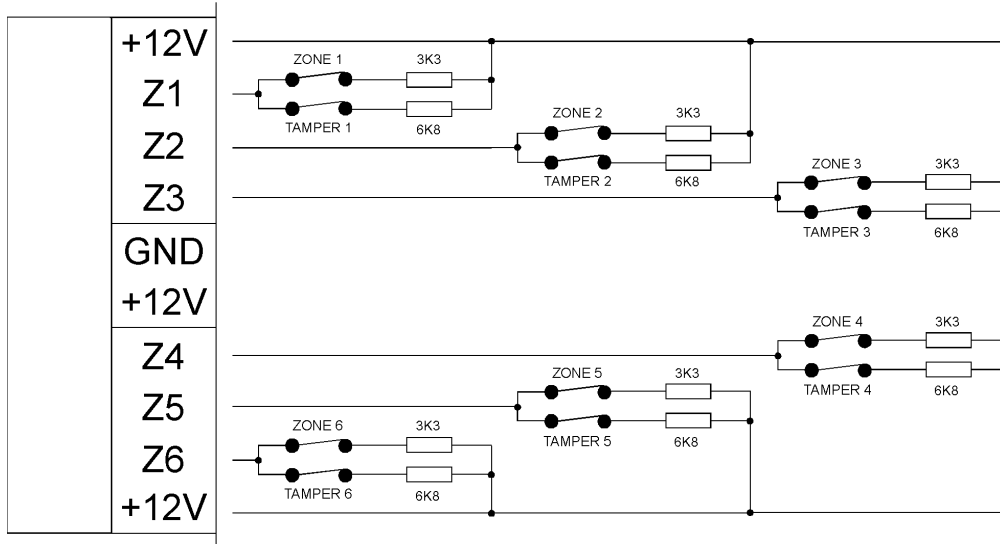

If N/O switches are used both zones will trip if either of the N/O switches are closed

Wiring Diagrams For Keyswitch Zones

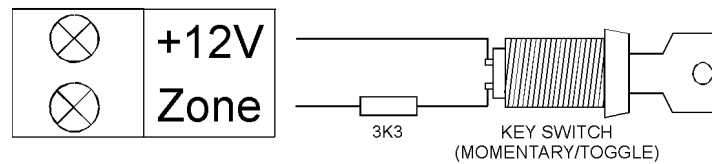

Figure 1: Wiring Diagram For Keyswitch Zone

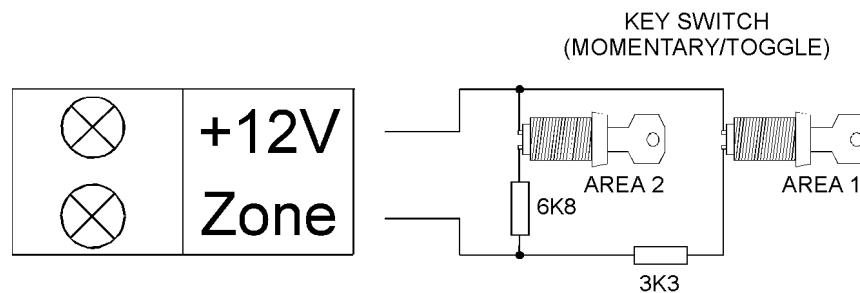
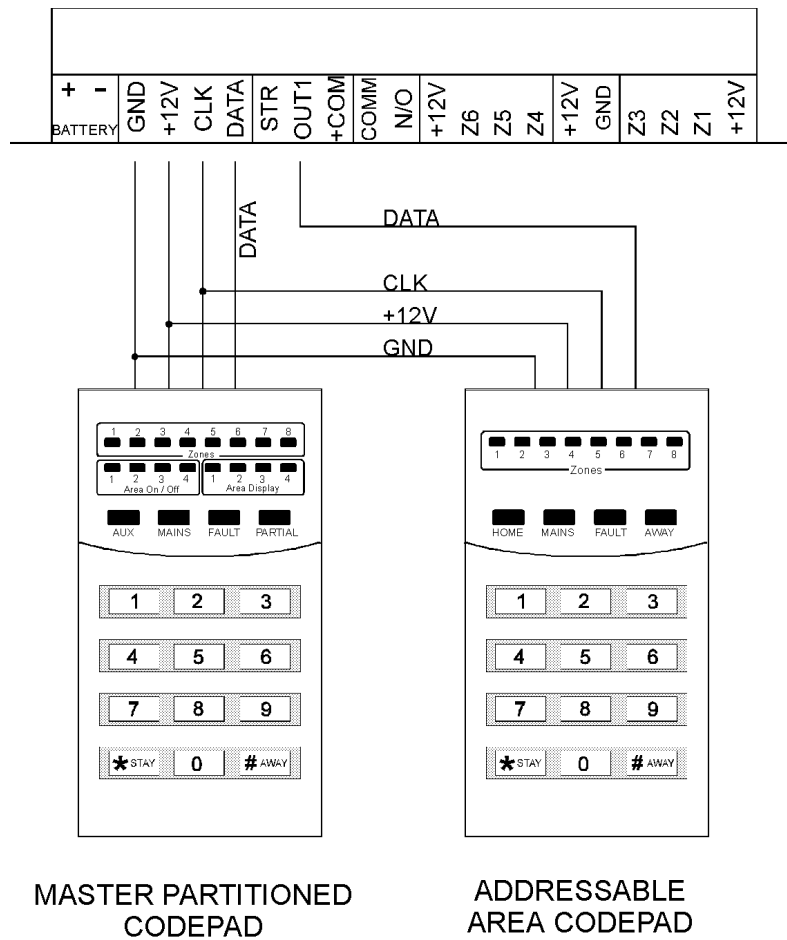

Figure 2: Wiring Diagram For Keyswitch Zone In Partitioning

Note 1: When choosing an EOL resistor value other than the default 3K3 for a non-partitioned system, the keyswitch zone must still use a 3K3 EOL resistor as shown in “Figure 1”. The keyswitch zone will not operate with any other resistor value.

Note 2: When using a keyswitch zone in partitioning, to enable arming/disarming of Area 2, there is no need to enable split EOL resistors when not using tamper zones. Simply wire the zone as shown in “Figure 2”.

Codepad Connections For Partitioned Systems



If the “Area Addressable” codepad is assigned to **Area 1**, DIP Switch 1 on the back of the remote codepad will need to be in the “ON” position. The following locations for Output 1 will need to be programmed.

[LOCATION 140 = 6, 141 = 0]

If the “Area Addressable” codepad is assigned to **Area 2** DIP Switch 2 on the back of the remote codepad will need to be in the “ON” position. The following locations for Output 1 will need to be programmed.

[LOCATION 140 = 6, 141 = 1]

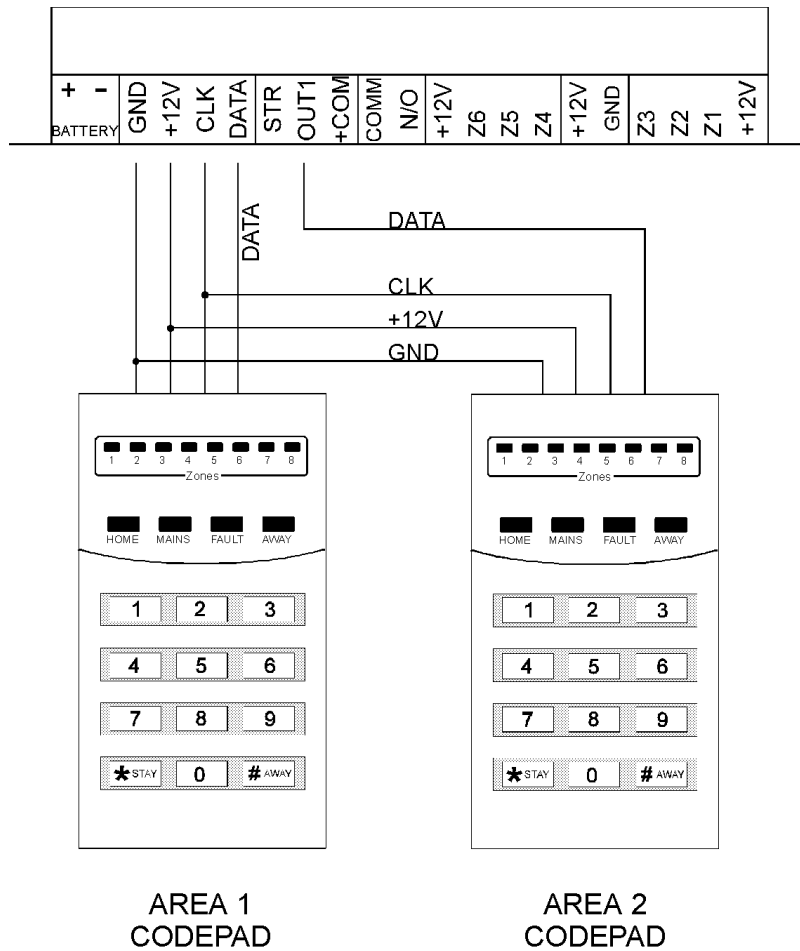

The following DIP Switch setting and locations must be programmed for the two “Area Addressable” codepads to function correctly.

Area 1 Codepad

DIP Switch 1 on the back of the remote codepad will need to be in the “ON” position. The following location will also need to be programmed.

[LOCATION 182, Option Bit 1 must be enabled]

Area 2 Codepad - (Output 1)

DIP Switch 2 on the back of the remote codepad will need to be in the “ON” position. The following locations for Output 1 will also need to be programmed.

[LOCATION 140 = 6, LOCATION 141 = 1]

Dear Customer

This Quick Reference Guide is supplied as a very limited document intended only to provide basic installer information. With this information you should be able to make the equipment operational in its simplest form provided you already have a basic understanding of the product. Installers who intend to make repeated installations are urged to purchase the full 200+ page installation manual which contains a wealth of information, diagrams and details the many outstanding features and benefits of the product.

Due to the size of this manual it is no longer practical for it to be included with every panel purchase. The cold hard facts are if the installation manual were to be included then the basic panel purchase price would increase to cover the extra costs.

The savings in panel costs will be multiplied with every new purchase and the benefits of having a detailed reference manual will save you countless dollars during your installation and service activities. Our environment also benefits from this policy as many installers would simply discard the surplus manuals. The cost of their disposal to the community, the trees required to produce the manuals in the first place and even the increased packaging costs all of which you the customer would be paying for.

Our surveys have found that 95% of installers are repeat product users and that there is nothing to be gained by having to pay for a manual with every panel. Instead we have made the installation manual a tool which is tax free to purchase and 100% tax deductible as a cost incurred in earning income.

It is obvious that the advantages of one manual for one installer greatly outweigh the disadvantages of not supplying an installation manual with every panel. I hope that this brief explanation shows that our intent is to save you money while still maintaining a superior standard of technical documentation.

Yours Sincerely

Meinrad Formosa

Managing Director



Electronics Design & Manufacturing Pty Limited

25 Huntingwood Drive
Huntingwood NSW 2148
Australia

A.C.N. 002 907 271

Phone: +612 9672 1777
Facsimile: +612 9672 1717
email: edm@edm.com.au
